

METAL ARC LAMPS

EmArc™



EmArc™ ENHANCED METAL ARC LAMPS

EmArc™ lighting technology is the culmination of a dedicated effort to bring together the inherent advantages of a number of gas discharge sources into a single light source. The technology equates to a critical blending of rare gas and metal additives to derive, in a single source, many of the key properties and benefits of stand alone Xenon, Metal Halide and Mercury lamps.

EmArc™ light sources are a series of highly efficient, Enhanced Metal Arc, DC gas discharge lamps designed for use in medical, scientific, industrial and entertainment settings. EmArc™ lamps are a progressive step ahead in lighting technology possessing features that offer advantages to an array of users for imaging, fiber optic and other important optical applications.

EmArc™ lamps have geometric designs which enable alignment in dichroic visible light or UV specific coated reflectors facilitating use in numerous applications like lighting for minimally invasive surgery,

curing of light sensitive resins and adhesives and, dental whitening procedures. EmArc™ versatility enables its use in a number of entertainment applications including searchlights, followspots, special effects and automated fixtures.

EmArc™ lamps are comparable to Metal Halide sources in luminous efficacy but with nearly 2 times to 5 times the life. A correlated color temperature like that of Xenon at 6000K, with very small arc gap sizes, but with nearly 2 times the luminous efficacy of Xenon lamps.

EmArc™ technology differentiates itself as a new family of discharge lamps.

APPLICATIONS

- Medical fiber optics for endoscopy or headlight illumination
- Biotechnology/ micro-array
- Industrial UV curing
- Machine vision
- Cosmetic dentistry
- Projection / Entertainment
- Microscopy
- Entertainment

High luminance at tip of cathode with DC arc discharge

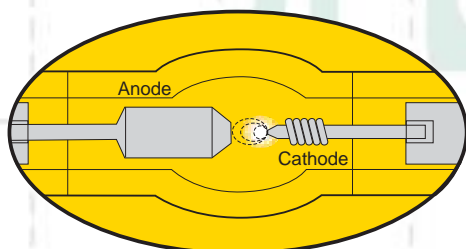

The construction of EmArc™ arc tubes, electrodes and precise filling technique provide the environment for the tightly confined plasma arc discharge. EmArc™ light output over time exceeds that of typical DC Xenon and AC short-arc Metal Halide lamps

See FEATURES & BENEFITS on back

EmArc™

DOUBLE ENDED BARE BURNER VERSIONS

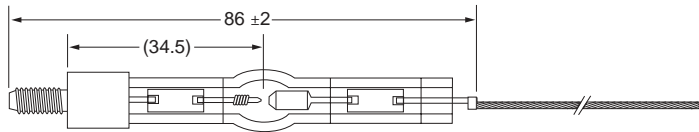

(1) SMH-200/D1

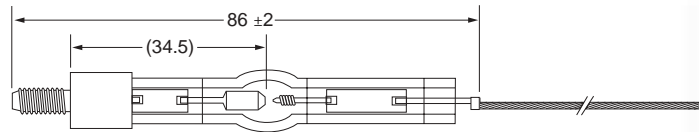

(2) SMH-200/D2

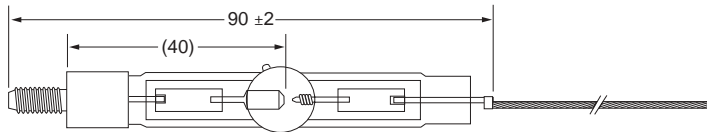

(3) SMH-270/D1

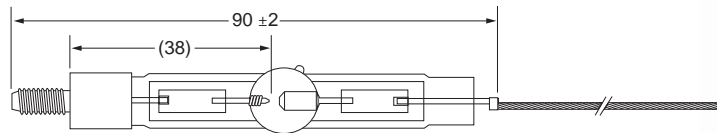

(4) SMH-350/D2

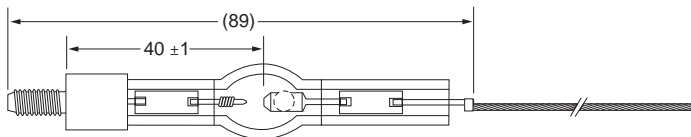

(5) SMH-600/D1

All dimensions are in millimeters

Wattage Power Range (W)	Ushio Lamp Code	Lamp Current (A)	Lamp Voltage (V)	Arc Gap (mm)	Luminous Flux (lm) nom	Avg Rated Life** (h)	Color Temp*** (K)	Fig No.
DOUBLE ENDED BARE BURNER VERSIONS								
150-200	SMH-200/D1	4.65	43	1.2	10000	2000	6000	1
150-200	SMH-200/D2	4.65	43	1.2	10000	2000	6000	2
270	SMH-270/D1	6.7	41	1.5	14000	2000	5700	3
350	SMH-350/D2	7.3	48	1.8	21000	2000	5400	4
600	SMH-600/D1	8.8	68	3.0	44000	1000	5700	5

** Based on 50% spherical lumen depreciation at a duty cycle of 2 hours 45 minutes ON and 15 minutes OFF

*** As measured in a sphere. All values ± 500K from nominal

EmArc™ REFLECTORIZED VERSIONS 70mm Reflector

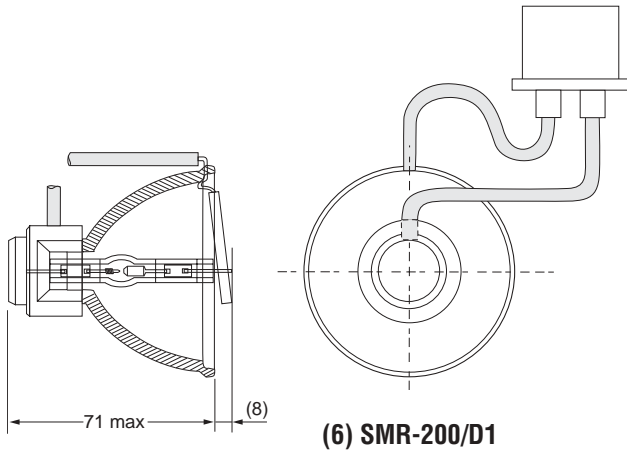

Lamp aligned for maximum throughput thru 6mm aperture at 52mm distance from reflector rim

All dimensions are in millimeters

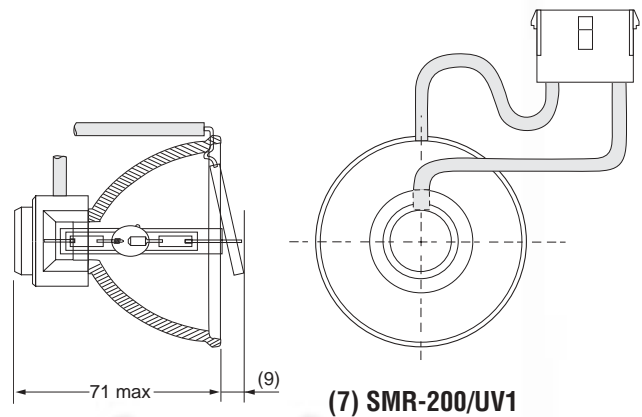
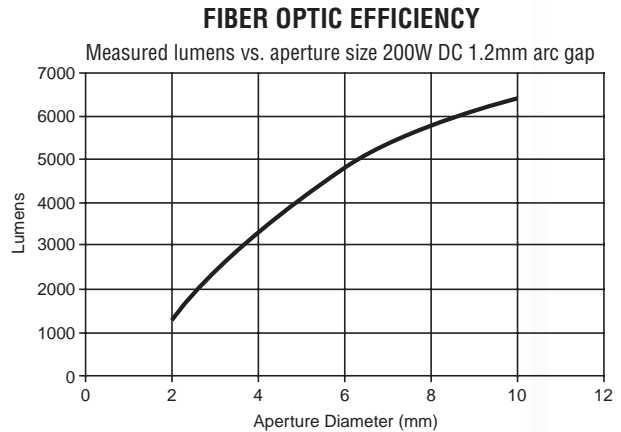

Wattage Power Range (W)	Ushio Lamp Code	Lamp Current (A)	Lamp Voltage (V)	Arc Gap (mm)	Luminous Flux* (lm) nom	Avg Rated Life ** (h)	Color Temp*** (K)	Fig No.
-------------------------	-----------------	------------------	------------------	--------------	-------------------------	-----------------------	-------------------	---------

REFLECTORIZED VERSIONS

150-200	SMR-200/D1	4.65	43	1.2	5100	2000	6500	6
150-200	SMR-200/UV1	5.0	40	1.2	—	—	—	7

* Based on measurement through 6mm aperture in a sphere

** Based on 50% spherical lumen depreciation at a duty cycle of 2 hours 45 minutes ON and 15 minutes OFF

*** As measured in a sphere. All values \pm 500K from nominal

EmArc™

ENHANCED METAL ARC TECHNOLOGY

FEATURES & BENEFITS

- Power ranges from 150-600 watts—
versatility/ power tunability
- Custom reflector designs available
- Small arc gap sizes—
down to 1.2mm highly effective optical collection
capability
- Unique hybrid gas discharge technology—
2,000 hours of life; no internal pressure when cold
- EmArc™ DC technology—
enables operation on lower cost DC power supplies
reducing OEM system design costs
- 6000K correlated color temperature—
Xenon-like light for crisp, white imaging
- Up to 60 lumens per watt efficacy—
nearly two times that of Xenon sources
- Highly durable, rugged elliptical and parabolic reflector
designs—
very high light path efficiencies for small diameter
fiber optic bundle applications
- Precise filling control, electrode design and tight
manufacturing tolerances with tipless arc tube
construction allows for tightly confined and stable
plasma discharge, long life with minimal color
temperature drift over life, better optical control, no
shadowing
- Far better color control over life than conventional
metal halide lamps
- Hot reignition

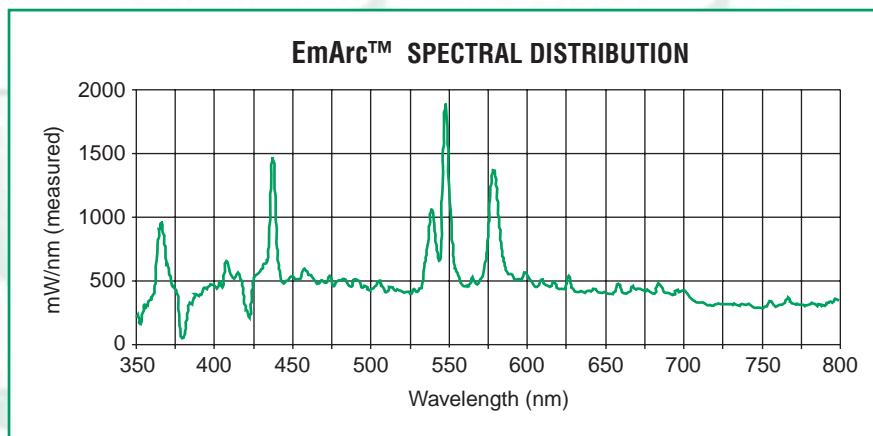

Form No. S-EmArc-1002: The specifications on this sheet supercede all previously published specifications and may be subject to change for design and specification improvement without prior notice.

hi-Tech lamps

800-229-6509

info@hi-techlamps.com